



BENCH WHEEL™
TECHNOLOGY

B-Board User Manual

Thank you for purchasing a BenchWheel longboard.

Do note that an electric longboard is not a toy, and takes time to learn. Please take the time to read this manual carefully, particularly the safety instruction pages.

We hope you will enjoy using this product and have lots of fun riding the longboard of the future!

BEFORE YOU RIDE

Ensure equipment is charged
Wear appropriate safety gear
Be aware of your surroundings
Ride in a safe area
Abide by local laws and regulations

Have fun and ride safe!

Getting Started

Charging

The board and controller need to be fully charged prior to first use. Ensure that both the board and controller are powered off when charging.

Notice: Using any other charger may cause damage to the control board or batteries, and will void your warranty.

Please contact us if you require a replacement charger.

Charging the longboard

Only use the supplied adaptor with the unit.

Power off the longboard if it is on.

Plug the supplied power adaptor into the power socket on the longboard.

The light on the charger will turn red while charging, and green when fully charged. Unplug the unit once the charge is completed.

It typically takes about 3 hours to fully charge the longboard batteries from empty.

Charging the remote controller

The controller uses a standard micro usb cable to charge.

Insert the supplied USB charge cable into the bottom of the remote controller. Make sure that the cable is oriented correctly when inserting into the controller.

Plug the other end of the USB cable into the charger, and plug into a power socket. It typically takes about 2 hours to fully charge the remote.

Pairing

On very first use, the board and controller need to be paired together.

Step 1:

Before starting the process, ensure that the controller and board are powered off.

- *Press and hold the red button on the controller briefly until the LED lights all turn off to power off the controller.*

- *Press and hold the red button on the longboard briefly until the power light turns off.*

Step 2:

Press and hold **both** the power button on the board, **and** the power button on the controller until you hear 3 beeps (1 long beep and 2 short beeps a few seconds later).

Step 3:

Power off both the board.

Power off the controller.

Power both back on again.

The board and controller are now paired.

If you fail to pair, repeat the process from step 1 until successful.

Testing Pairing

You can test pairing by placing the longboard on its side, and pushing up on the motion controller until the wheel motors engage and the wheels start spinning. Push backwards on the motion controller to stop the spinning.

The board is now ready to use.

Before you ride

- Prior to use perform a quick visual check that the board looks ok, and equipment is undamaged.
- Ensure that you have appropriate safety gear.
- Find a safe environment to use the longboard in.

First Ride

Power up the unit and check that everything is running smoothly. Engage the brake by pressing downwards on the motion controller. Step onto the board, find your balance, and gently push up on the controller until the board starts rolling. The more you push up on the controller, the faster you will travel. Pushing downward on the controller will engage the brakes. Practice going forward slowly until you feel comfortable, then try turning. We suggest learning with a friend initially, so that you have support in case you fall.

Most users will be able to ride competently within a short period of time. It's easier than you think!

Basic Riding Tips

Remember to press down on the controller to engage the brake. This makes mounting the longboard a lot easier for beginners. You should place the foot that you kick with to the rear of the board, and your other foot to the front of the board. Keep to a pace that you are comfortable with until you are experienced using the board. Learn to turn by gently leaning your feet forwards to turn left, and backwards to turn right whilst moving forwards.

Remember, practice makes perfect!



FAQ

Issue	Possible Reasons/	Solution
Failure to start unit.	Battery out of power	Longboard: Please charge immediately. It generally takes 3 to 4 hours. Remote controller : please charge immediately. It generally takes 2 hours.
Riding time/ cruise duration is short	Battery are not fully charged	Please fully charge the longboard battery. It generally takes 3 to 4 hours to fully charge the unit.
Battery isn't charging	Plug cable is loose	Ensure that the cable to the charger and the wall is firmly plugged in. The charger will turn red when charging, and green when the longboard is fully charged.
	Battery needs replacement	The average battery life is between 1 to 2 years depending on condition and use. Replace only with Benchwheel board replacement batteries.
Longboard doesn't run when motion controller pressed upward.	Indicator③ or ④ flashing on remote controller indicates no connection to longboard.	Start up longboard.
	Indicator③ and ④ flashing on remote controller indicates a fault in longboard	Restart longboard and remote controller. If indicator③ and ④ still flash, please turn off the units and consult your dealer or Benchwheel.
	Indicator on B-board flashing(not match code) indicates a fault in B-board	Please consult your dealer or Benchwheel.
	A flashing indicator② indicates a low battery capacity.	Please charge the longboard
	When indicator② pulses on and off slowly , the controller is out of battery power.	Please charge the remote controller.
Auto power-off	Battery power insufficient	Please charge the longboard.
	The board and remote will automatically power if left unused for a few minutes.	Press the power button on the longboard and the remote to start the unit.



Specifications

Complete Skateboard	Net weight	7.9kg
	Product size	920mm*240mm*280mm
	Packaging	1090mm*290mm*350mm
Deck	Material	3 layers bamboo 2 layers fiber glass
	Size	1090mm*233mm*14mm
Battery Pack	Capacity Type	8.8AH
	Type	Lithium-Ion
	Weight	1320g
	Charge Time	3 hours
	Rechargeable	1000 times
Motor Pack	Type	Brushless direct current
	Power	1800w Dual motor
Wheel	Material	High performance PU
	Dimensions	80mm*45mm
	Hardness	78a
Wireless Remote Controller	Capacity	800mA
	Type	Lithium-Ion
	Charge Time	120 minutes



Component Parts - Board

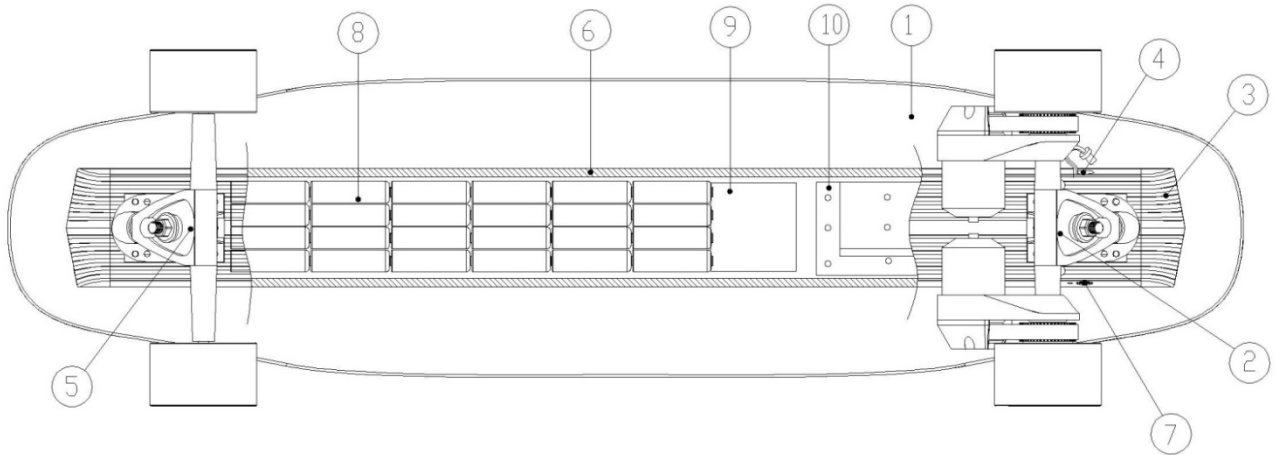

- 1 Deck
- 2 Powered Truck set
- 3 Plug
- 4 Charge Port
- 5 Unpowered Truck Set
- 6 Aluminum case
- 7 Power Button
- 8 Lithium-Ion Battery Pack
- 9 Battery Protection Module
- 10 Control Board



Powered truck set

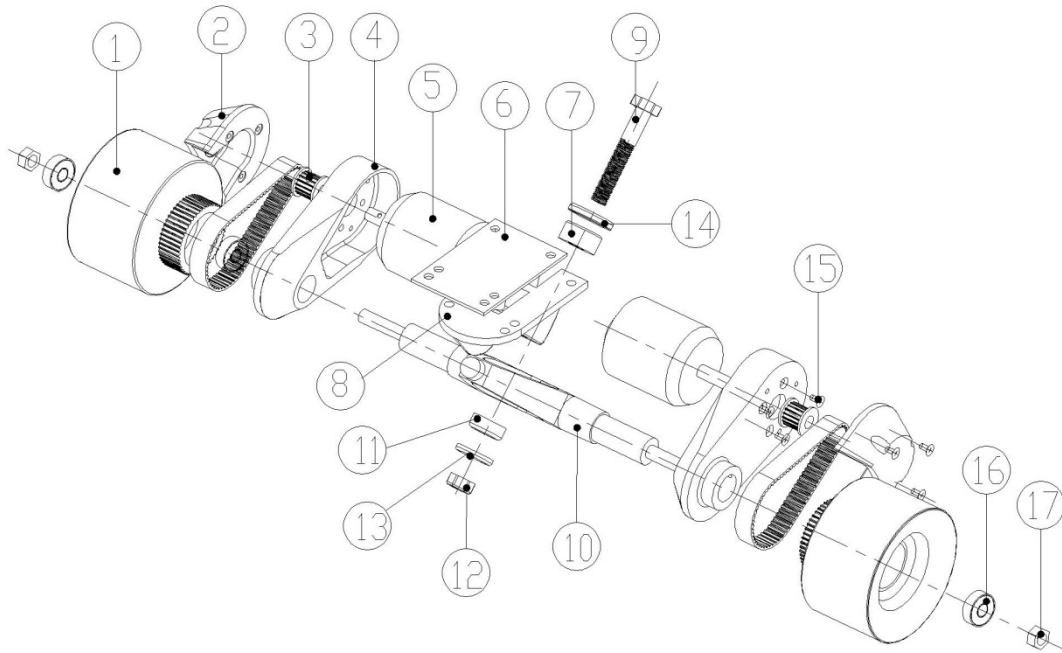

- 1 Synchronous wheel
- 2 Cover
- 3 Synchronous pulley
- 4 Motor holder
- 5 Brushless direct current motor
- 6 Truck shim
- 7 Spring washer
- 8 Holder
- 9 Truckbolt
- 10 Truck
- 11 Spring washer
- 12 Nut
- 13 Gasket ring
- 14 Gasket ring
- 15 Countersunk screw
- 16 Bearing
- 17 Nut



Unpowered truck set

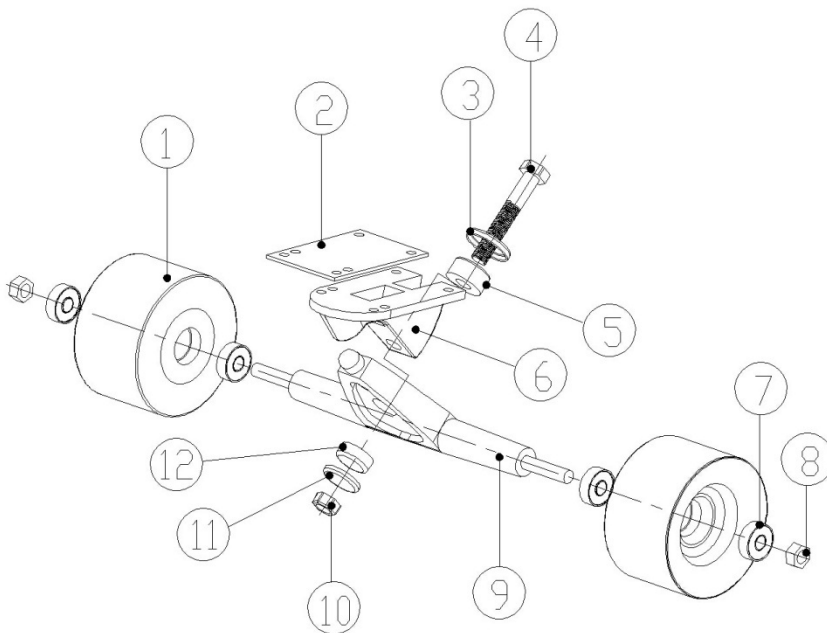

- 1 Wheel
- 2 Gasket
- 3 Gasket ring
- 4 Truckbolt
- 5 Spring washer
- 6 Holder
- 7 Bearing
- 8 Nut
- 9 Truck
- 10 Nut
- 11 Gasket ring
- 12 Spring washer

Remote Control

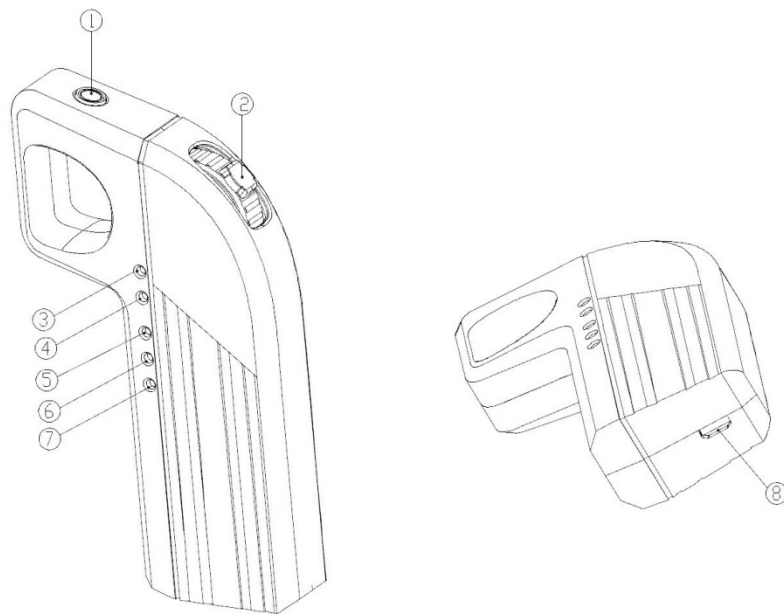

- 1 Power Button
- 2 Motion Controller
- 3 Low speed indicator light
- 4 High speed indicator light
- 5 Battery charge level indicator light #1
- 6 Battery charge level indicator light #2
- 7 Battery charge level indicator light #3
- 8 Remote Control charge port (MicroUSB)

Safety Instructions

- An electric longboard is not a toy, and should be treated with appropriate care.

Always practice safety first - as it is possible to lose balance and cause a collision or fall, ensure that you use the board in a safe appropriate environment, and you always wear appropriate safety gear.

- Safety Gear - we recommend that you wear full safety gear when riding.
Please wear a suitable skateboard helmet, elbow pads, knee pads, and gloves. Wear suitable attire when skateboarding to protect you from scrapes if you fall. Wear shoes - flipflops or similar loose footwear are not suitable riding wear.
- The board is designed for use by responsible riders of the ages 13 and up.
- Only one person can ride a B-Board at a time.
- The maximum carrying weight supported by the board is 120kg/260lbs.
Exceeding this weight will affect the B-board balance and functionality, and may cause the board to fail, act inappropriately or otherwise break.
- Please observe your local traffic laws and regulations.

- Do not drive under the influence of drugs or alcohol.
- The board is designed to be ridden on flat and paved surfaces.
Avoid driving on sand, gravel, mud, rugged or open ground.
Do not drive on slippery ground, such as snow, ice or wet ground..
- Keep a safe distance from other people and stationary objects while riding.
Do not drive in crowded spaces - you could be a danger to yourself and other people.
- Do not ride at night or in dark unlit locations.
- Always be aware of your surroundings.
Please pay attention when riding a board and always be on the lookout for other road users or dangers.
Avoid listening to music when riding, as other road users may not be heard until too late.
- Perform a basic safety check of the board before riding to avoid accidents or equipment damage.
Check the bolts and trucks are tightly fastened.
Check electrical connections are firmly connected.



Ensure the drive belts are undamaged and the chassis is clean of obstructions.

- Please don't place any items on top of the board when riding.
- When the board is low on power, the low power light will display.

Please stop using the board and recharge the battery as soon as possible.